

## Communications & Power Industries Power Coupler Product Specification

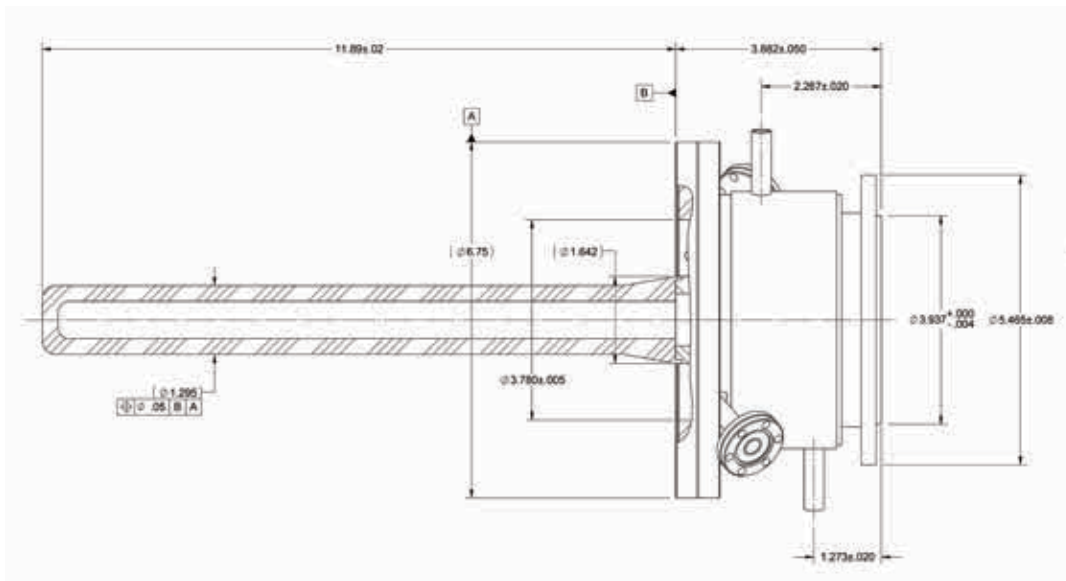
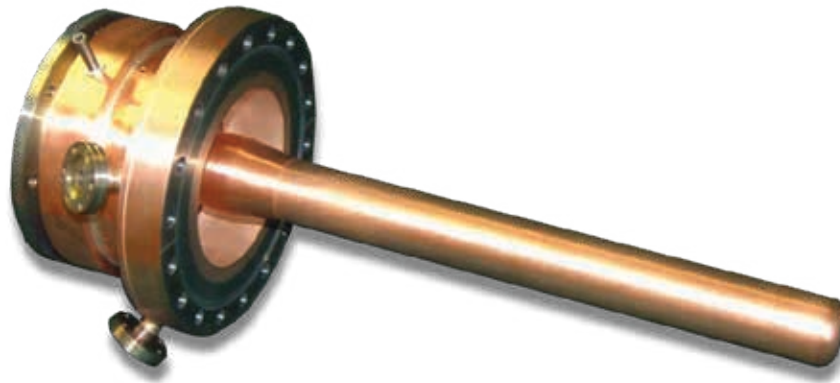

The VWP3143 Power Coupler was designed for ORNL's upgrade to the SNS system, as a higher power variant to the original VWP1133.

### FEATURES:

- 805 MHz
- Water cooled outer conductor
- Conductively cooled inner conductor
- Single coaxial window coupler for SCRF applications
- Capacitively coupled

# CPI 805 MHz ORNL SNS Power Coupler product specification: VWP3143

## Electrical Parameters

Operating frequency	805 MHz
Maximum CW power:	700 kW CW peak 65 kW average
Vacuum leak rate	$< 10^{-10}$ mbar.L/s
Assembly sealing type	Conflat gasket
Cold assembly outer conductor diameter	3.780 Inches
Water cooling	Outer conductor

Product can be cleaned in CPI's class 10 clean room after fabrication for an additional charge. If the product is not cleaned in CPI's class 10 clean room, it will need to be done by the customer before the product is conditioned.

